

---

**Interfacing with PacSci SC900 Series Drive and  
the OC950 Programmable Single Axis Position  
Control Option Card**



**Wiring & Software Setup**

## Setup

Prepare OC950 for RS232 Modbus communications.

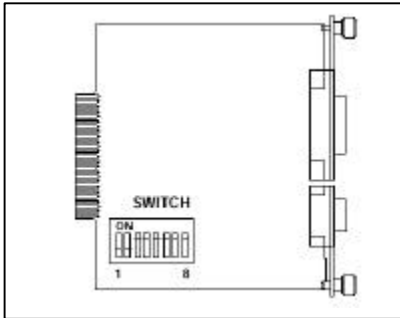

The OC950 has unique address that can be used to access multiple units using Modbus RTU in a multidrop situation. The OC950 unit ships with a default address of 255 which is not a valid modbus address. In order to communicate with the Eason the address must be changed on the OC950 to be in a range of 1-254. Addresses are set corresponding to an inverted binary representation.

For example to set the address of the unit to 1 the binary representation of 1 is 00000001. This inverted is 11111110. So the dip switches are set to the following configuration.

1	2	3	4	5	6	7	8
OFF	ON	ON	ON	ON	ON	ON	ON

Once the switches are set put the OC950 back into the drive and hookup a serial cable from a PC to OC950 using the following RS232 cable.

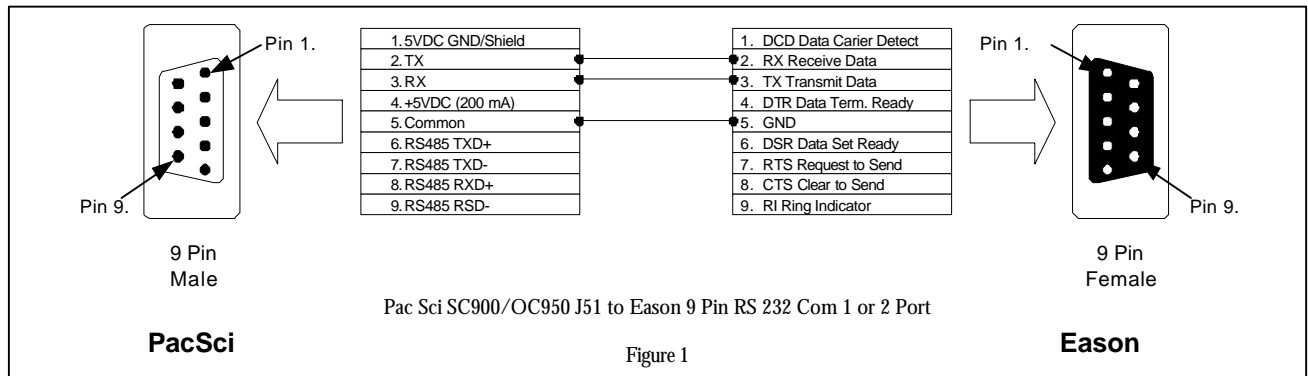

Establish communications with the unit using the Pacific Scientific's 950 Development Environment software. Further information on how to do this can be found in their *MA950 OC950 Installation and Hardware Reference Manual*. The OC950 is programmed in PacSci's ServoBasic. For instructions on programming the OC950 please



refer to the *MA950-LR 950BASIC Reference Manual* Specifically Section 1.11 on Modbus communications.

The Eason unit will act as the master and the OC950 should be configured as a slave. The following program sets up the OC950 to be a Modbus slave and map certain predefined variables into 4000 objects. The program sets RuntimeProtocol = 2 which is for Modbus RTU.

<pre> params '----- Parameter Values Header ----- ' ' Drive:                &lt;unknown&gt; ' Motor:                &lt;unknown&gt; ' Performance Setting: &lt;unknown&gt; ' Inertia Ratio:       &lt;unknown&gt; '----- params start ----- ' ARF0      = 150.006729 ARF1      = 750.005798 Commoft   = 0.000000 CommSrc   = 0 ILmtMinus = 100.000000 ILmtPlus  = 100.000000 ItThresh  = 50.000000 Kip       = 144.432999 Kpp       = 15.000631 Kvi       = 4.993019 Kvp       = 0.062366 Polecount = 4  BDIOMap1  = 0 BDIOMap2  = 0 BDIOMap3  = 0 BDIOMap4  = 0 BDIOMap5  = 0 BDIOMap6  = 0 RuntimeProtocol = 2  '----- params end ----- end params '----- program info ----- programinfo   \$PacLanAddr(1)  'allow download only to axis 255 end programinfo </pre>	<pre> '----- Define (dim) Global Variables - '----- Main Program ----- '----- ' Modbus Map Definitions '----- MBInfo   \$MBMapFloat( 40001, ARF0 )   \$MBMapFloat( 40003, ARF1 )   \$MBMapFloat( 40005, Kip )   \$MBMapFloat( 40007, Kpp ) end MBInfo '----- main   'print "Starting Main"   RuntimeProtocol = 2   While 1 = 1   Wend   'print "Ending Main" end main  '----- Subroutines and Functions ----- '----- Interrupt Routines ----- </pre>
---	--

Figure 2

The OC950 serial communications use the RS232/422 interchangeably. To talk with an Eason using the Modbus RTU connect to the OC950 using RS232 or RS422. The following drawings show the correct cable configurations for each.

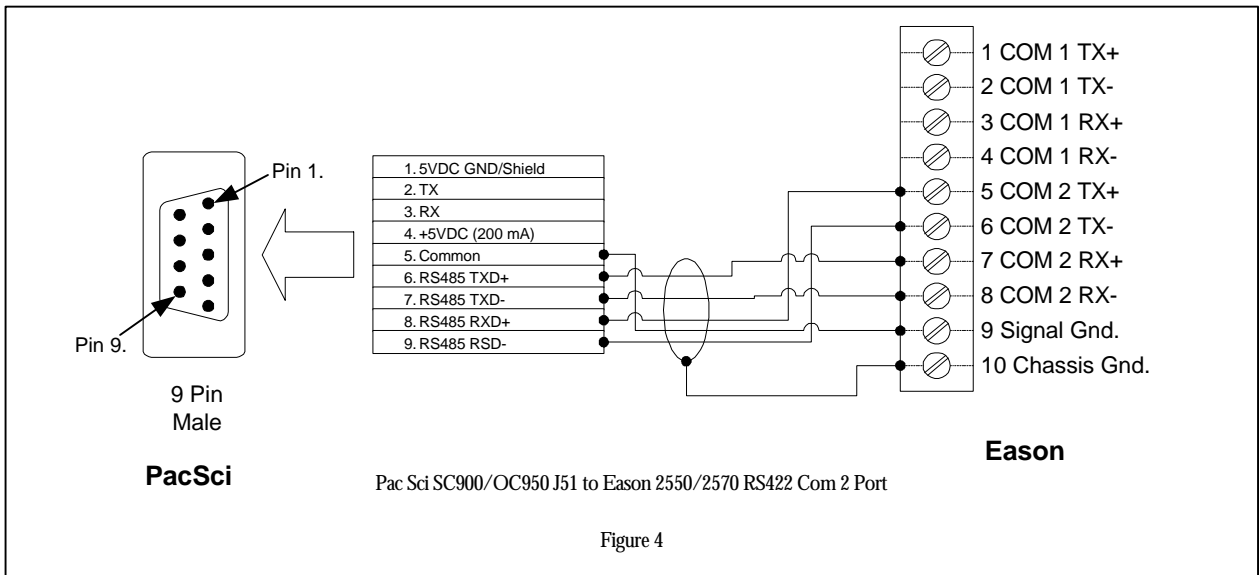
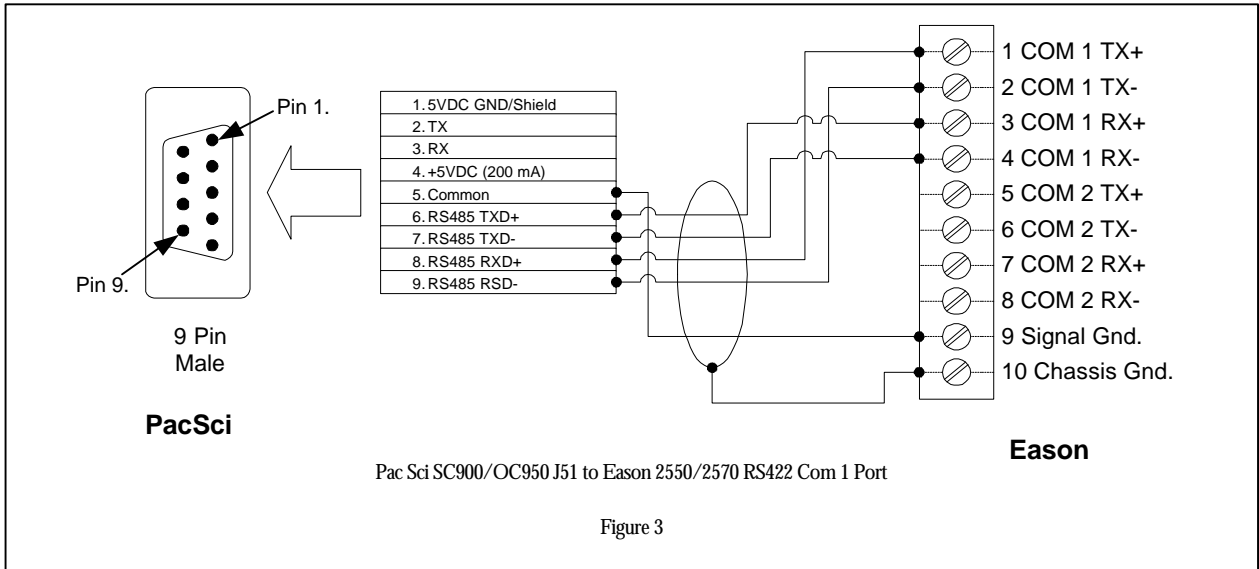

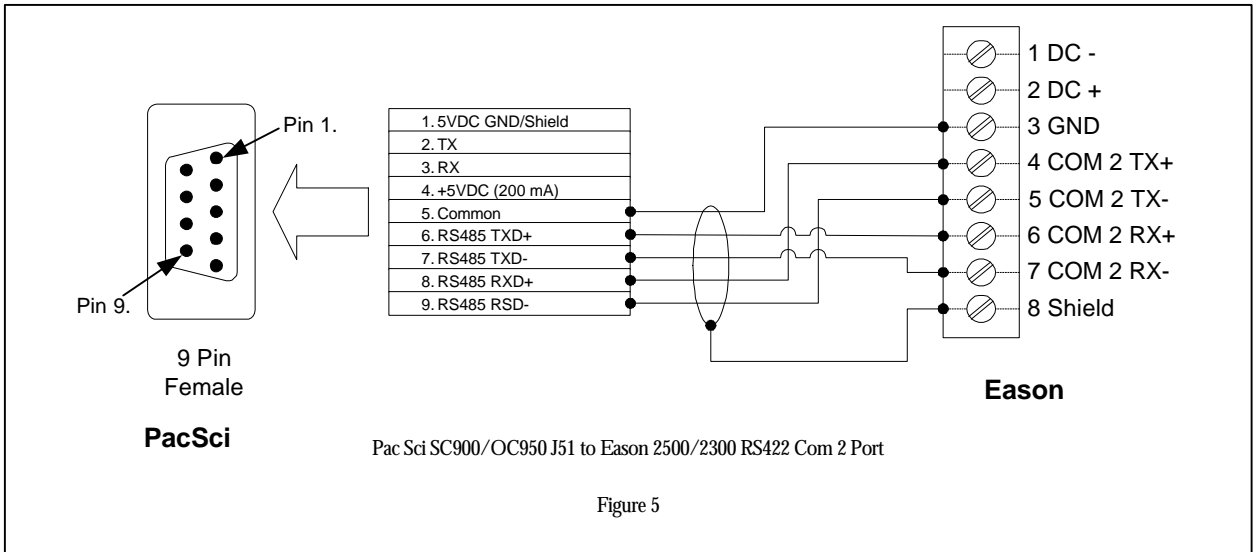

See also "PacSci.oip" demo program included in the "examples" directory in WinBuild 2000.